

PDG Mobility™

Product catalog



permobil

Fuze Family

Width-adjustable aluminum wheelchair frames with 50° tilt for effortless positioning. Lightweight and compact design offers easy setup, full adjustability and compatibility with a wide range of seating accessories and wheelchair options.



Specifications

	Fuze T50	Fuze T50n	Fuze T50 Junior
Dynamic Tilt Range	Up to 50°	Up to 50°	Up to 50°
Seat Width	13" - 24"	16" - 24"	12" - 18"
Seat Depth	15" - 22"	15" - 22"	13" - 18"
Seat to Floor Height	13" - 20"	16" - 20"	13" - 20"
Overall Width	+7.5" - 8.5"	+4.0"	+7.5" - 8.5"
Transport Weight	44 lbs	44 lbs	42 lbs
User Weight Capacity	400 lbs	400 lbs	250 lbs
Material	Aluminum	Aluminum	Aluminum
Power Tilt Option	Yes, up to 350 lbs	Yes, up to 350 lbs	-
Take apart	Yes	Yes	Yes
Hand Propulsion	Yes	-	Yes
Foot Propulsion	-	-	-
Self-Tilt	-	-	-
Transit Tiedowns	Yes, up to 300 lbs	Yes, up to 300 lbs	Yes

Fuze M50 (Canada Only) 

Specifications

Dynamic Tilt Range	Up to 50°
Seat Width	15" - 24"
Seat Depth	16" - 22"
Seat to Floor Height	13" - 19"
Overall Width	+ 8.5"
Transport Weight	52 lbs
User Weight Capacity	400 lbs
Material	Aluminum
Power Tilt Option	-
Take apart	-
Hand Propulsion	Yes
Foot Propulsion	-
Self-Tilt	-
Transit Tiedowns	Yes, up to 300 lbs



Take-Apart

The Take-Apart frame allows attendants to take the Fuze apart in seconds without tools. This feature reduces the weight of the heaviest piece of the wheelchair to 29 lbs or less. Perfect for transporting it in the trunk of a car or SUV.

Exclusive features

- Simple three-step operation that can be performed in seconds without any tools
- No need to remove seating from the chair (note: seating increases weight beyond 29 lbs)
- Once taken apart, a full-size chair will fit into the trunk of an SUV or sedan

Available for

- Fuze T50
- Fuze T50n
- Fuze JR



Scan for more information and a video on take apart

T50 vs T50n
Overall chair width for 20" seat width

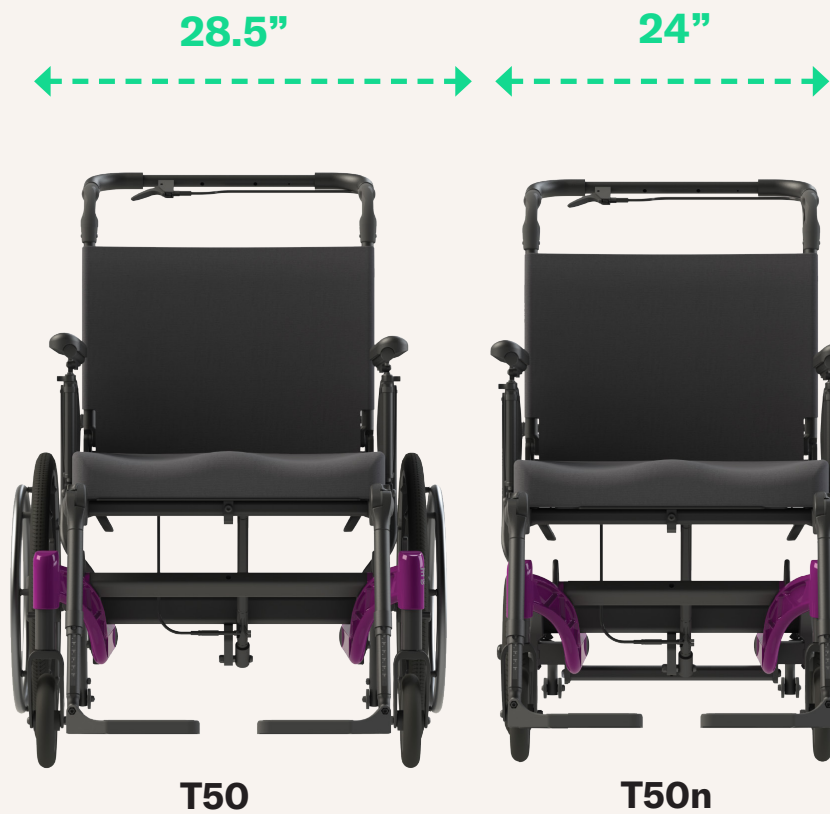

50° tilt in space with the footprint of a transport chair

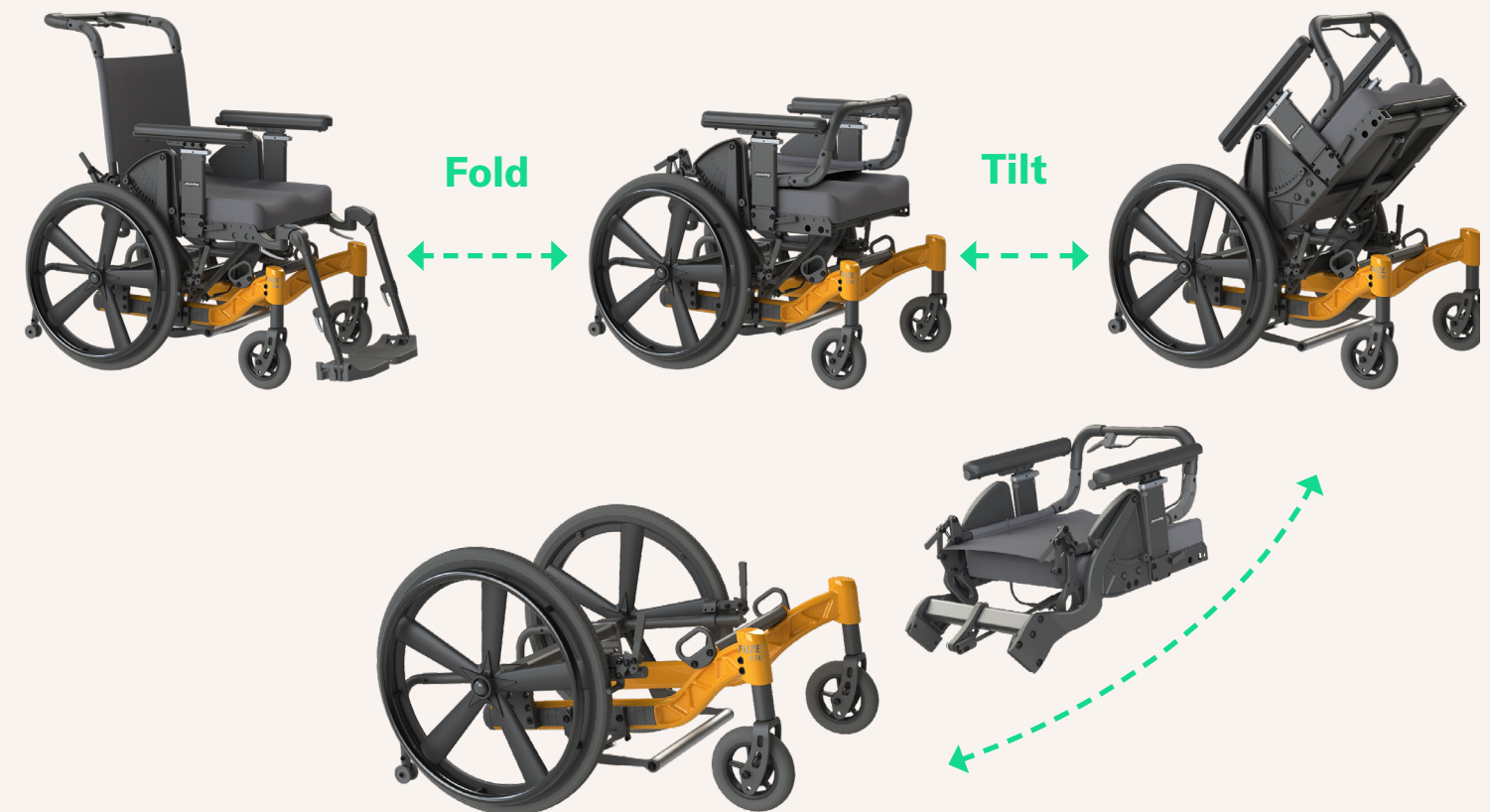

Stellar Family

45° tilt with low knee rise promotes self propulsion, improved table access and participation in mobility related activities of daily living. Rigid frames provides superior stability and maneuverability.



Specifications

	Stellar GL	Stellar GLT	Stellar Impact
Dynamic Tilt Range	-5° to 45°	-5° to 45°	Up to 45°
Seat Width	14" - 32"	14" - 24"	14" - 22"
Seat Depth	16" - 22"	16" - 22"	17" - 22"
Seat to Floor Height	13" - 20"	13" - 20"	14" - 21"
Overall Width	+9.5" - 10.5"	+9.5" - 10.5"	+9.5" - 10.5"
Transport Weight	51 lbs	34 lbs	64 lbs
User Weight Capacity	450 lbs	300 lbs	250 lbs
Material	Steel	Aluminum	Steel
Power Tilt Option	Yes, up to 250 lbs	Yes, up to 250 lbs	-
Take apart	-	-	-
Hand Propulsion	Yes	Yes	Yes
Foot Propulsion	Yes	Yes	Yes
Self-Tilt	Yes	Yes	Yes
Transit Tiedowns	Yes, up to 300lbs	Yes	Yes



Specifications

	Stellar HD
Dynamic Tilt Range	Up to 45° (25° @ 600)
Seat Width	22" - 32"
Seat Depth	18" - 22"
Seat to Floor Height	16" - 18"
Overall Width	+ 11"
Transport Weight	62 lbs
User Weight Capacity	600 lbs
Material	Steel
Power Tilt Option	-
Take apart	-
Hand Propulsion	Yes
Foot Propulsion	Yes
Self-Tilt	-
Transit Tiedowns	-



The lightweight design of the Stellar GLT combines the benefits of 45° tilt with a high degree of mobility independence.

Bentley Family

20° tilt with zero knee rise, allowing users to keep their feet on the ground for stability or propulsion. Compatible with both self and power tilt options.



Specifications

	Bentley	Bentley LT	Bentley LT-R
Dynamic Tilt Range	Up to 20°	Up to 20°	Up to 20°
Seat Width	14" - 32"	14" - 24"	14" - 24"
Seat Depth	16" - 22"	16" - 22"	16" - 22"
Seat to Floor Height	13" - 20"	13" - 20"	12" - 19"
Overall Width	+9.5" - 10.5"	+9.5" - 10.5"	+10.5"
Transport Weight	51 lbs	44 lbs	34 lbs
User Weight Capacity	450 lbs	300 lbs	300 lbs
Material	Steel	Aluminum	Aluminum
Power Tilt Option	Yes, up to 250 lbs	Yes, up to 250 lbs	Yes, up to 250 lbs
Take apart	-	-	-
Hand Propulsion	Yes	Yes	Yes
Foot Propulsion	Yes	Yes	Yes
Self-Tilt	Yes	Yes	Yes
Transit Tiedowns	Yes, up to 300 lbs	Yes	Yes

Eclipse

The Eclipse is a rigid chair designed for the bariatric user and supports up to 1000 lbs of occupant weight. Extended casters achieve optimal weight balance on the rear wheels for excellent ease of propulsion.

Primary functions

- Desk/Table accessible
- Transit tie downs
- Hand propulsion
- Foot propulsion

Available options (see order form)

- Transit tie downs WC-19 & ISO-7176-19
- 30° manual dynamic recline



Specifications

Dynamic Tilt Range	No tilt	Power Tilt Option	-
Seat Width	20" - 48"	Take apart	-
Seat Depth	16" - 24"	Hand Propulsion	Yes
Seat to Floor Height	14" - 20"	Foot Propulsion	Yes
Overall Width	+ 7.5"	Self-Tilt	-
Transport Weight	44 lbs	Transit Tiedowns	Yes (up to 600 lbs)
User Weight Capacity	1000 lbs		
Material	Steel		

Frame colors

High gloss paint

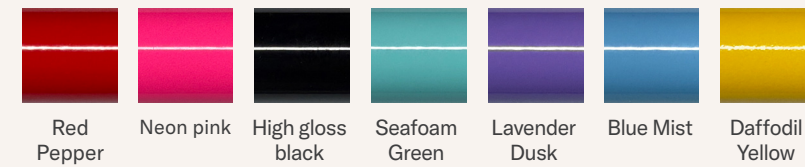

Pearlescent paint



Matte textured paint

Candy paint

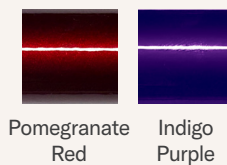

Metallic paint

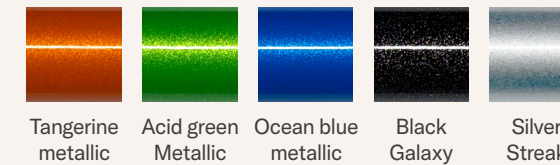

Matte paint

